

# Series PXL

Flows to 170 GPM  
Pressure to 118 Ft. TDH



Model PXL-5A-3

## Penguin Extended Length Vertical Pump

### Features:

- Pump Lengths of 2 and 3 feet
- Corrosion-Resistant CPVC with 316SS or Titanium Shaft & Teflon Bearing
- Water or Product Flushed Bearing
- Chemical-Resistant Motor
- Teflon Vapor Seal

### Recommended Applications:

- Sump Pumping
- Transfer Pumping
- Recirculation Pumping
- Plating Solution Filtering
- Waste Treatment

Our Penguin extended length vertical immersible pump is compact, portable, and self-priming. Simple in design and efficient in performance, this pump has only one moving part. With a CPVC pump housing and impeller, a 316 stainless steel shaft, and a teflon bushing, this pump is suitable for pumping, agitating, and filtering, or for circulating acid and alkaline solutions (pH 0-14), abrasive fluids, and other corrosive mixtures. The maximum temperature rating is 190°F.

The solid 316 stainless steel motor is securely threaded to a special NEMA frame motor and also to a CPVC or PVDF impeller with a keyed 316 stainless

steel molded insert. As an option, titanium shafts and inserts are also available.

The Penguin extended length vertical pump is equipped with a totally enclosed fan cooled (TEFC) motor with an oversized bearing set for easy replacement and an epoxy coating for acid resistance. All motors are shipped unwired.

Our extended length vertical pump is versatile, easy to install, and requires a minimal amount of tank space, thus saving valuable floor area.

# Series PXL

## Penguin Extended Length Vertical Pump

### Specifications

Model	Max Flow (gpm)	Max Head (ft)	Suction	Discharge	Motor					Dimensions				
					HP	RPM	Volts	Hertz	Phase	Amps	Ht	Wth	Lth	Wt
P-3	150	88	2 FPT	1 1/2MPT	3	3450	208-230/460	50/60	3	8.2-7.8/3.9	18	18	*	C/F
P-5	172	118			5					12.2-11.6/5.8				

### Dimensions

Model	A	B	C	D	E	F	G
P-3	6	7	*	2 5/8	2 1/4	**	9 1/2
P-5							

\* Length varies by model. See housing length in nomenclature.

\*\* Add 19" to C for F dimensions.

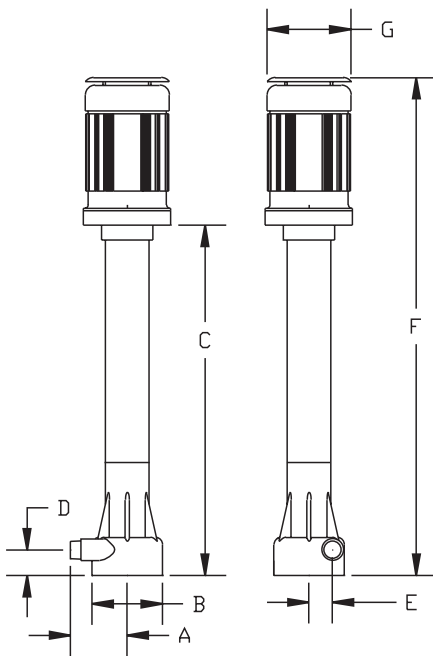

### Performance

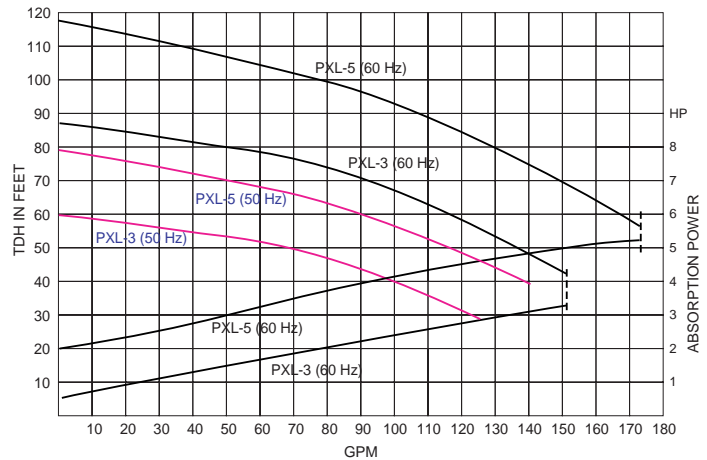

### Nomenclature

PXL	3	A	3		
Penguin	Horsepower	Construction Material/ O-Ring Elastomer Material	Housing Length	Shaft Material	Mounting Plate w/ Discharge Pipe
Extended	3=3	A=CPVC/EPR	2 = 2'	None=316SS	Assembly (DPA)
Length	5=5		3 = 3'	T=Titanium	None = None
Vertical					M = DPA
Pump					
Series					

Your Stocking Distributor:

Chemical Distributors, Inc. - Buffalo, NY - 800.777.2436 - Fax 716.856.7115

