

# Series PX

## Installation & Maintenance

**Models:**

**PX-3**

**PX-5**

**PX-7 1/2-HF**

**PX-10-HF**

**PX-15-HF**

**Materials:**

**A - CPVC**



## ***Introduction***

Penguin Pumps are designed to handle a large range of chemicals without difficulty. Completely constructed of CPVC where in contact with the solution being pumped, Series PX pumps have an upper working temperature of 180 degrees and thus can handle slurries, and most corrosive and abrasive solutions. Series PX pumps are easy to install and operate, and are virtually maintenance-free. All pumps have been tested for proper operation before leaving the factory. To obtain optimum service life, please follow all installation and operating instructions.

# *Installation & Operating Instructions*

---

## **ELECTRICAL**

---

All models are supplied with three phase dual voltage, 208-230/460V, 50/60c motors, which are not wired at the factory. When changing from 230V wiring to 460V wiring, follow the motor manufacturer's wiring instructions, which can generally be found either on or in the motor junction box. Since direction of rotation cannot be determined without operating the pump, **the pump head and snap ring must be removed prior to bump starting**. It is imperative that the motor rotation be checked before operation. Attach leads to motor and bump start for a maximum of a couple of seconds as if you were turning a light switch on/off as fast as possible. Do not leave motor running. As viewed from the suction entrance of the pump, check for counterclockwise rotation. If clockwise rotation, change any two hot leads and again check rotation. Replace head and snap ring as described in Assembly. Many options are available on the PX Series motors including explosion-proof, larger horsepower to 15, and 575V motors. If any of these options are required, please check the motors carefully or consult the factory.

## **PLUMBING**

---

The suction side piping of the pump is extremely important. Mistakes can usually be compensated for if made on the discharge piping. However, piping problems on the suction side can be, and usually are, the source of ongoing and expensive problems, which could be very difficult to track. If a suction line or suction extension is required, enlarge the suction line/extension by one size larger than the suction entrance. Never reduce plumbing on the suction. Avoid 90-degree elbows and never use a 180-degree elbow. The suction piping needs to be arranged in such a way as to allow a straight, even flow of liquid into the eye of the impeller. This requires that all elbows, valves, or strainers be located at the straight and uninterrupted distance equal to at least 5-10 times the pipe diameter. Remember, elbows create turbulence and air entrapment. Make sure every suction coupling/connection is airtight. The bottom of the suction extension should always be at least 2 pipe diameters above the bottom of the tank. In either flooded suction or non-flooded suction conditions, the use of a check valve on the discharge of the pump is recommended. In the case of a non-flooded suction, a flapper check valve on the end of the submerged suction line must be installed. To facilitate priming the pump, install a T-connection with a small valve between the pump case and check valve. It is advisable to use a discharge valve after the check valve. All plumbing and accessories must be supported other than by the pump, in order to prevent possible distortion of the pump case. The use of some hose in the discharge plumbing close to the discharge nozzle of the pump will absorb any movement of the solid plumbing if vibrations exist. Also a good rule of thumb is that the source solution tank volume should be three times the flow rate of the pump.

## **LIQUID LEVEL**

---

The correct liquid level is very important. A liquid level which is too high could cause motor damage. A liquid level that is too low, below the wear ring, may cause severe impeller damage, **THIS PUMP CANNOT RUN DRY. CHECK THE LIQUID LEVEL**. The correct liquid level is halfway between the bung hole and the centerline of the discharge nozzle.

## **PRIMING**

---

Under flooded conditions, open all the valves in the suction and discharge lines. Wait a few minutes to let entrapped air out. Throttle the discharge valve 2/3 closed. Leave suction valves wide open. A closed suction or discharge valve could cause damage to the impeller and the shaft. Start the pump and open the valve to the desired flow. Under non-flooded conditions, fill up the pump slowly from the T-connection and valve. See recommended installation. Then throttle the discharge valve 2/3 closed. Start the pump and continue as flooded conditions.

## **RECOMMENDATIONS**

---

Always make sure there is enough liquid in the reservoir and that the level is high enough, considering the capacity of the pump unit. Inadequate liquid will cause a vortex in the reservoir. A vortex occurs when air mixes from the surface into the fluid, which can disturb the flow and can also prevent the pump from priming. Therefore, a rule of thumb is to maintain a minimum of 2ft. of suction pipe submergence in order to prevent the formation of vortices. Suction pipe velocities should not exceed 5ft/sec. In cases where the pump is installed outside the reservoir, do not run against a closed discharge valve for more than 1 minute. This will cause overheating of the fluid in the pump and will damage the CPVC parts. Temperature in this case will increase up to 220 degrees. If the pump is being run against a closed discharge valve for a long duration of time, install a small bleed line back into the reservoir before the discharge valve of the pump. If the line is small, there is a minimum pressure loss. This prevents overheating by recirculating the fluid.

# Recommended Installation

## High Liquid Level

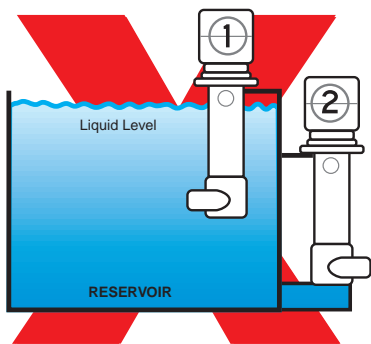

**In Tank** - Solution may pour out of weep hole during operation

**Out of tank** - Solution will pour out of weep hole and may flood motor when not in operation

## Low Liquid Level

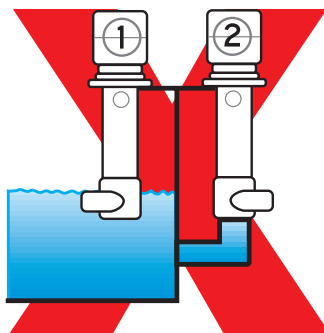

Non-flooded conditions. Pumps will not pump

## Recommended

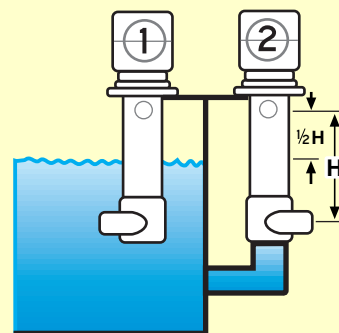

Liquid level halfway between discharge and weep hole

## Suction Level

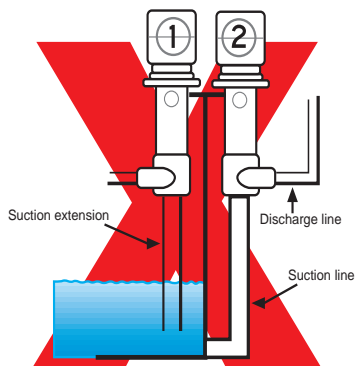

Solution level below impeller. Pumps will not pump

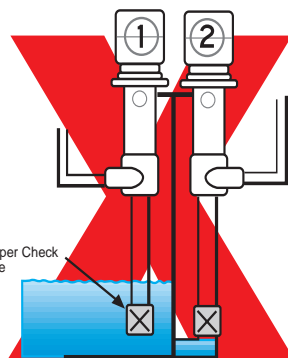

Check valves installed to maintain level. Not good to prime pumps

## Recommended

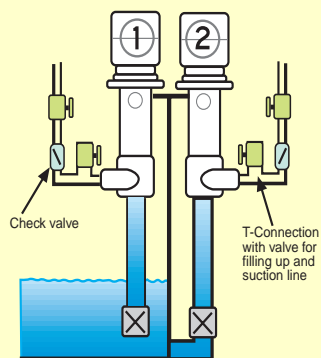

Solution level below impeller with priming tee. Check valve and throttling valve

## Suction Head

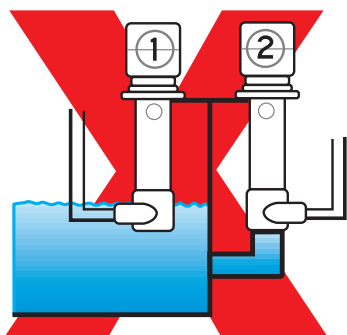

Solution level at impeller. No suction head available

## Recommended

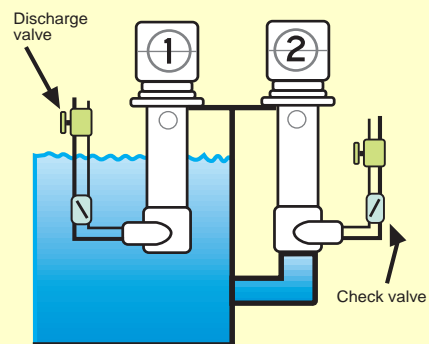

Solution level above impeller. Suction head available

**Recommended installation for optimal performance and endurance.**

**KEY**

- Out-Of-Tank Installation
- In-Tank Installation
- Valve
- Check Valve
- Flapper Check Valve

# Spare Parts List

## PX-3-HF

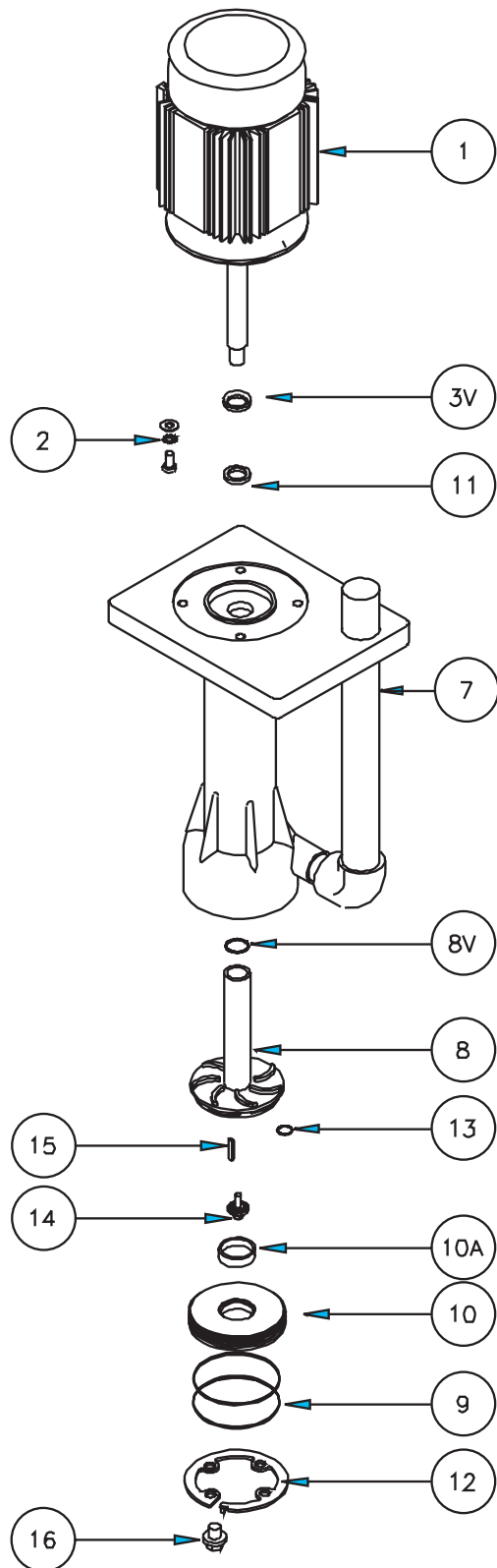

## PX-10-HF

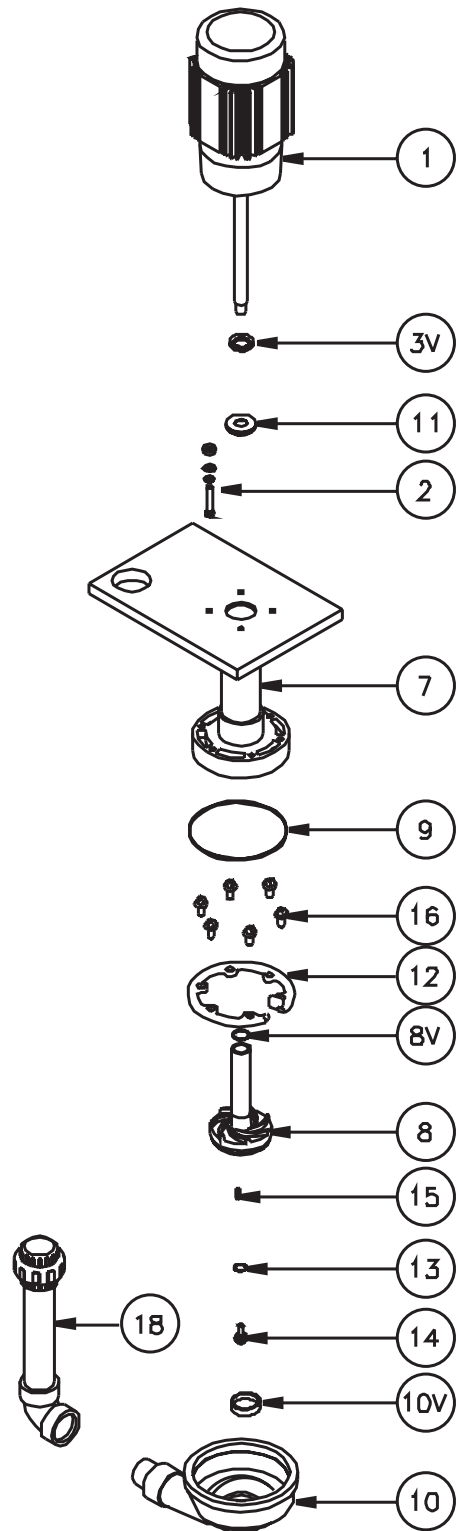

# Spare Parts List

Item	Description	PX-3A	PX-5A	PX-7 1/2A-HF	PX-10A-HF	PX-15A-HF
1	Motor/Shaft Assy phase - volt - cycle 3 208-230/460 50/60	PX-300-3103	PX-500-3103	PX-712-3103	PX-010-3103	PX-015-3103
1BS	Bearing Set	P-300-01BS			P-015-01BS	
1EF*	External Fan w/Set Screw	P-300-01EF			P-015-01EF	
1FC*	Fan Cover (w/Drip Shield)	P-300-01FC			P-015-01FC	
2	Motor Screw/Standoff Ass'y	PX-300-05 (4)			P-015-05(4)	
3	V-Seal	P-300-02			P-015-02	
7A	Pump Housing Assy - CPVC	PX-300-06A			PX-015-06A	
8	Impeller - CPVC	PX-300-07A	PX-500-07A	PX-712-07A	PX-010-07A	PX-015-07A
8V	Impeller Sleeve O-Ring - Viton	P-300-07AV			P-015-07AV	
8E	Impeller Sleeve O-Ring - EPR	P-300-07AE			P-015-07AE	
9V	Head O-Ring - Viton	P-300-11V (2)			P-015-11V	
9E	Head O-Ring -EPR	P-300-11E (2)			P-015-11E	
10	Head Assy w/ Wear Ring - CPVC	PX-300-10A			PX-015-10A	
10P	Wear Ring - PTFE	PX-300-10A2			PX-015-10A2	
11V	Lip Seal Assy	P-300-13V			P-015-13V	
12A	Snap Ring - CPVC	P-300-12A			P-015-12A	
13V	Impeller Nut O-Ring - Viton	P-300-08VK			P-015-08V	
14A	Impeller Nut Assy - CPVC	P-300-09AK			P-015-09A	
15T	Shaft Key - Titanium	P-300-15K			P-300-15K	
16A	Snap Ring Bolts - CPVC	P-300-16A (4)			P-015-16A(6)	
18A	Discharge Plumbing - CPVC	PX-300-18A**			PX-015-18A	
19A	Pump Head Assy - CPVC	PX-300-14A	PX-500-14A	PX-712-14A	PX-010-14A	PX-015-14A

\* Specify Motor Manufacturer

\*\* Included in Pump Housing Ass'y

# Maintenance Instructions

## **PX-3A and PX-5A**

### **DISASSEMBLY**

1. Remove the four (4) snap ring screws. Now the snap ring can be removed using a screwdriver or a pair of pliers.
2. Insert a 2 inch threaded pipe through the center hole at the end of the housing to remove the head. Pull with a rocking motion to remove. Caution must be used because of the close tolerance between the impeller and wear O-ring. Head O-rings can easily be replaced.
3. Unscrew the fan cover screws and remove the fan cover and drip shield. Place the screwdriver between fan blades and unscrew the impeller nut using a 3/4 inch open wrench in a counterclockwise rotation. Impeller nut O-ring can be replaced.
4. With the pump in a vertical position, impeller up, place a screwdriver through the discharge port, wedging between the impeller top and the housing. Carefully lift the impeller and remove. If impeller does not remove easily, proceed to step 5.
5. Remove the four (4) motor bolts located beneath the motor bracket. Motor and housing are now separated. Do not try to remove shaft as this is an integral piece with the motor rotor. Slinger and lip seal can be replaced. Using a rubber mallet, hit the pump bracket lightly, top side facing motor, until the impeller and keyway pop loose.

### **ASSEMBLY**

1. With the motor in a vertical position, shaft upwards, place the four motor spacers over the motor bolt holes. Place housing over shaft, lining up motor bolt holes in the mounting bracket with holes in the motor. Be sure the V-Seal slinger is properly in place. Screw the motor bolts into the holes beneath the mounting bracket in a diagonal sequence.  
Be sure motor screws are tight.
2. Insert the impeller into the housing until it bottoms out. Do not hammer the impeller and sleeve down on the shaft. Line up the keyway and insert key by lightly tapping it with a hammer. Screw the impeller nut clockwise holding impeller. Be sure impeller nut O-ring is properly in place. After handtight, turn with wrench 180 degrees.  
**DO NOT OVERTIGHTEN.**
3. Replace the fan cover and drip shield. Insert the fan cover screws and tighten. Be sure fan is not rubbing against fan cover.
4. Place the pump upright resting on the motor. Look down into the housing and, while rotating the impeller, check to see that the impeller is centered. The impeller must not be touching the side of the housing.
5. Wet head and head O-rings. Be sure head O-rings are properly in place. Insert 2 inch threaded pipe into the head and replace in housing. The threaded pipe should be tapped with a mallet, pushing the head into the housing until the snap ring groove is exposed. Remove pipe and replace snap ring. Line up through holes in snap ring with the threaded holes in the head by rotating the snap ring counterclockwise. Insert and tighten the four (4) snap ring screws.

## **PX-7 1/2A-HF thru PX-15A-HF**

### **DISASSEMBLY**

1. Unscrew and remove discharge piping. Remove the six (6) snap ring screws. Now the snap ring can be removed using a screwdriver or a pair of pliers.
2. With a rubber mallet, gently hit the back of the suction casing, alternating blows from one side to the other until the suction casing comes off. Suction casing O-ring can easily be replaced.
3. Unscrew the impeller nut using a 3/4 inch socket wrench in a counterclockwise rotation. Impeller nut O-ring can be replaced.
4. Thread a 3/4-10UNC bolt into the hole in the center of the impeller eye. Holding the impeller, using an appropriate wrench turn the bolt clockwise until the impeller slips off the shaft.

### **ASSEMBLY**

1. Unscrew the fan cover screws and remove the fan, fan cover, and drip shield assembly. In order for the motor to stand on end, the fan shaft must be placed in a hole deep enough for it to sit flat on the end bell. With the motor in a vertical position, shaft upwards, place the four motor spacers over the motor bolt holes. Place housing over shaft, lining up motor bolt holes in the mounting bracket with holes in the motor. Be sure the slinger is properly in place. Screw the motor bolts into the holes beneath the mounting bracket in a diagonal sequence.  
Be sure motor screws are tight.
2. Using loctite or other type of threadlocker, secure key into keyway on shaft. Insert the impeller into the housing. Rotate to engage key and slide or lightly tap into place until it bottoms out. Do not hammer the impeller and sleeve down on the shaft. Screw the impeller nut clockwise holding impeller. Be sure impeller nut O-ring is properly in place. After handtight, turn with wrench 180 degrees.  
**DO NOT OVERTIGHTEN.**
4. Place the pump upright resting on the motor. Look down into the housing and, while rotating the impeller, check to see that the impeller is centered. The impeller must not be touching the side of the housing.
5. Lubricate support casing and casing O-ring. Be sure casing O-ring is properly in place. Slide suction casing over support casing, lining up timing marks to assure proper fit. Using a soft mallet, tap suction casing down onto support casing until snap ring groove is exposed. Line up through holes in snap ring with the threaded holes in the support casing by rotating the snap ring clockwise. Insert and tighten the six (6) snap ring screws.



Chemical Distributors, Inc.  
80 Metcalfe Street • Buffalo, NY 14206  
Voice: (800) 777-2436 • Fax: (716) 856-7115