

FNTM Drum Gauge

FNTM 55 Gallon Drum Gauge

- Waterproof self-contained housing to ensure contaminate-free monitoring.
- AA battery powered, provided.
- Touch gauge sides to activate LEDs
- Displays drum levels from 90% to 5%.
- Alerts when the drum level is below 5%
- Low battery alert
- Audible low battery indicator chirp.
- PVC and ABS Plastics Construction.
- FNTM is designed to be used in standard metal 55 gallon drums.
- Fits in 3/4" NPT vent opening.
- Simple installation.
- Easy battery replacement.
- Audible alert.
- Less expensive than comparable monitors
- 2 plus year battery life

New 55 Gallon Drum Alert

MODEL NO.	DESCRIPTION	SHIPPING WEIGHT LBS (KG)
10807	FNTM 55 Gallon Drum Gauge	1.0 (0.45)



FNTM Drum Gauge

FNTM 55 Gallon Drum Gauge

Dimensions

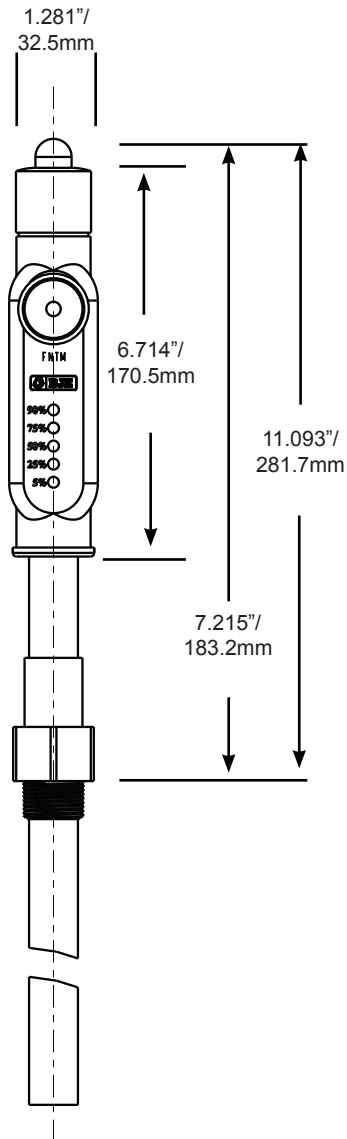

CHEMICAL DISTRIBUTORS, INC.



80Metcalf Street • Buffalo, NY 14206
(800) 777-2436 • Fax (716) 856-2300

www.cdibuffalo.com • sales@cdibuffalo.com

MADE IN THE U.S.A. 