

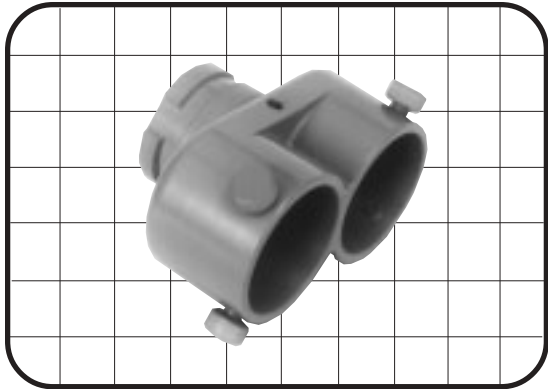

FLO KING MULTIPLE CARTRIDGE HOLDERS



Double Cartridge Holder

*Included with BXL2500, BX3000, BXL5000 & BX5000.
Available as Accessory for BX650 and BX1200.*

VERSATILITY FOR YOUR FILTER SYSTEM

- Maximize filter surface area in solution
- Increase dirt-holding capacity
- Change filters less frequently
- Increase flow rate
- Great for shallow tanks and heavily used solutions

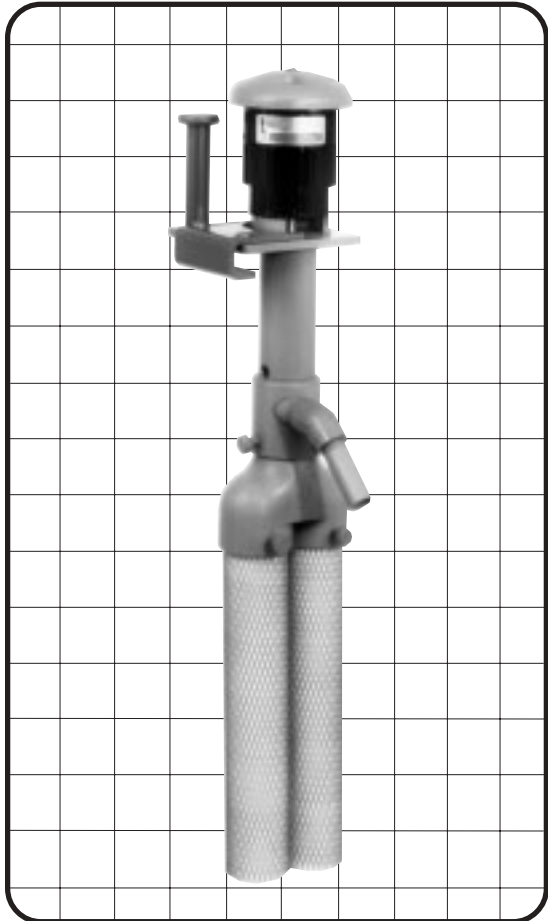

**QUAD
Cartridge Holder**

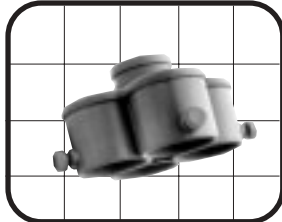

*Use Four Filters
Instead of Two*

**Extended Double
Cartridge Holder**

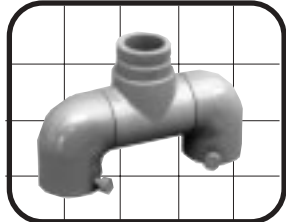

*Filter and Carbon Treat
Or Use with Two Quads*

