



FLO KING IN-TANK LAB SERIES FILTER SYSTEM

For tanks as small as a half-gallon and larger!

At last . . . an in-tank filter system small enough to use in a half-gallon (2-liter) beaker as well as tanks up to several gallons. Your choice of three filter cartridge sizes, plus the ease of clamping to most existing beakers and tanks using an adjustable bracket.

Pumps from a few gallons to 400 gallons per hour (up to 1,500 liters/hour)

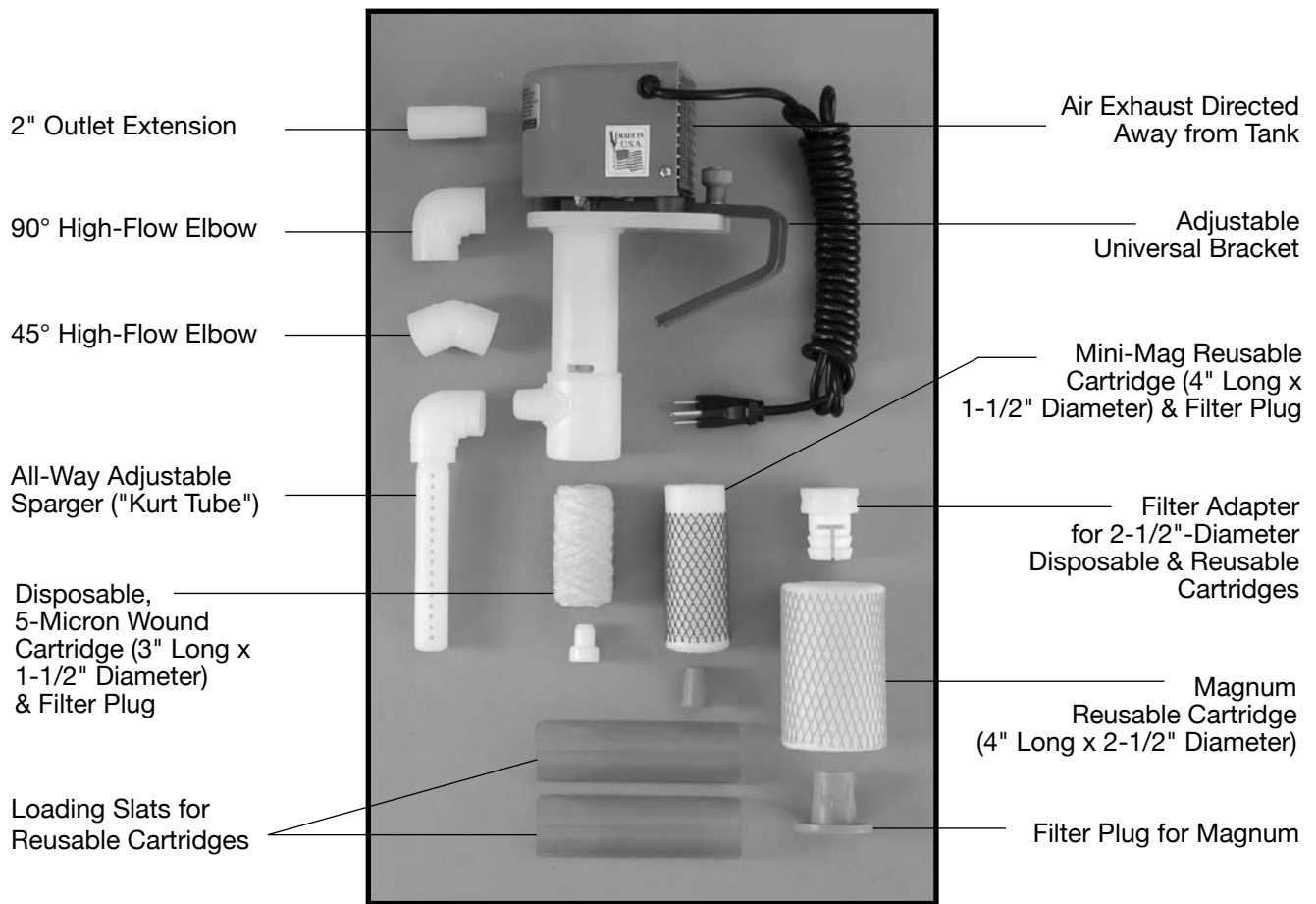

This is a ready-to-operate filter system complete with all accessories illustrated. It is powered by a super-quiet, ball-bearing, continuous-duty motor.

★ IF YOU NEED A FILTER SYSTEM TOMORROW CALL US TODAY ★

Distributed By: ★ www.cdibuffalo.com ★ sales@cdibuffalo.com

CDI Equipment Division • 80 Metcalfe Street, Buffalo, NY 14206 USA • 716.856.2300 Fax 716.856.7115

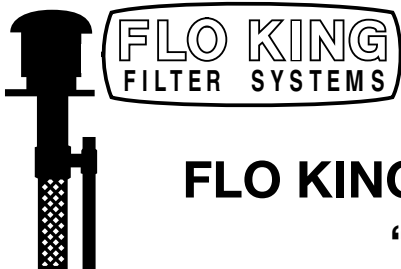

FLO KING IN-TANK LAB SERIES FILTER SYSTEM

“Tomorrow’s Filter Technology Today”



Introducing THE IN-TANK CONCEPT in small bath filtration—the **Flo King** Lab Series system. This unit is ideal for laboratory, prototype, and small-tank production operations in clean settings. Like all **Flo King** systems, it is a complete, pre-assembled unit that uses no out-of-tank apparatus and cannot leak or spill.

The Lab Series is small enough to filter a half-gallon beaker, yet powerful enough to use in small plating and related tanks—generally up to about 10 gallons (40 liters) but sometimes more, depending on agitation requirements, type of solution, and other factors. The flow rate is dependent on the filter element and attachments selected and ranges from a few gallons to 400 gallons per hour (1,500 liters per hour).

The Lab Series includes attachments to meet diverse agitation needs—two elbows for high flow and a directable dispersion tube (“Kurt Tube”) for gentle, uniform circulation.

Three filter cartridge sizes are provided to satisfy many filtration requirements. The two Magnum filter cartridges are capable of filtering down below 1 micron and are reusable. The Poly-Wrap is a 1-1/2"-diameter disposable cartridge. In addition, a simple-to-attach Filter Adapter included in the Lab Series package enables the use of any standard 2-1/2"-diameter cartridge, including the popular high-quality **Flo King** Poly-Spun disposables.

Our adjustable Universal Bracket allows the filter system to be mounted easily on most tanks without the use of tools. The bracket also provides a secure mount on round beakers and glass battery jars.

The Lab Series filter system is a ready-to-use package requiring no tools or training to operate. It is supplied in 115 or 230 volts for your electrical needs and in different pump-body lengths to satisfy the depth and freeboard of your container or tank. For sizing suggestions, just provide the information requested on Bulletin 12.1.

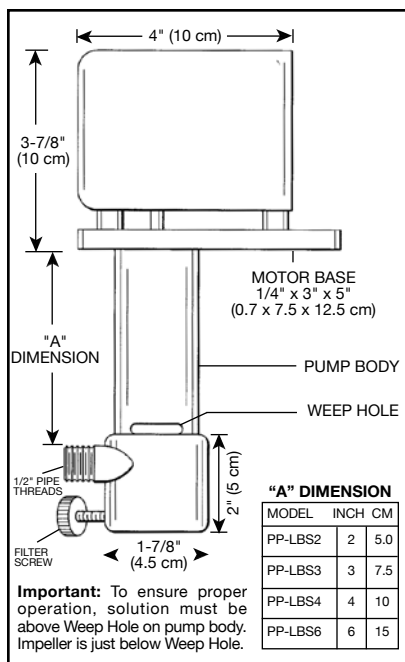

FLO KING LAB SERIES SPECIFICATIONS

PUMP: Standard unit is made of polypropylene with Teflon-covered 303 stainless-steel shaft. Pump also available on special-order basis in PVDF (Kynar), stainless steel, and CPVC. Titanium shaft also available (call for pricing).

FLOW RATE: Up to 400 gallons per hour (1500 liters per hour) at 60 Hz, depending on type of filter cartridge and attachments used. A flow-rate reduction of 18% (±3%) is typical when operated at 50 Hz.

MOTOR: 1/70th horsepower (11 watt), single phase, thermally protected. When ordering, specify one of the following motors:

- 115 volts, 50/60Hz, 2600/3000 RPM, 0.96 A
- 230 volts, 50/60Hz, 2600/3000 RPM, 0.48 A