

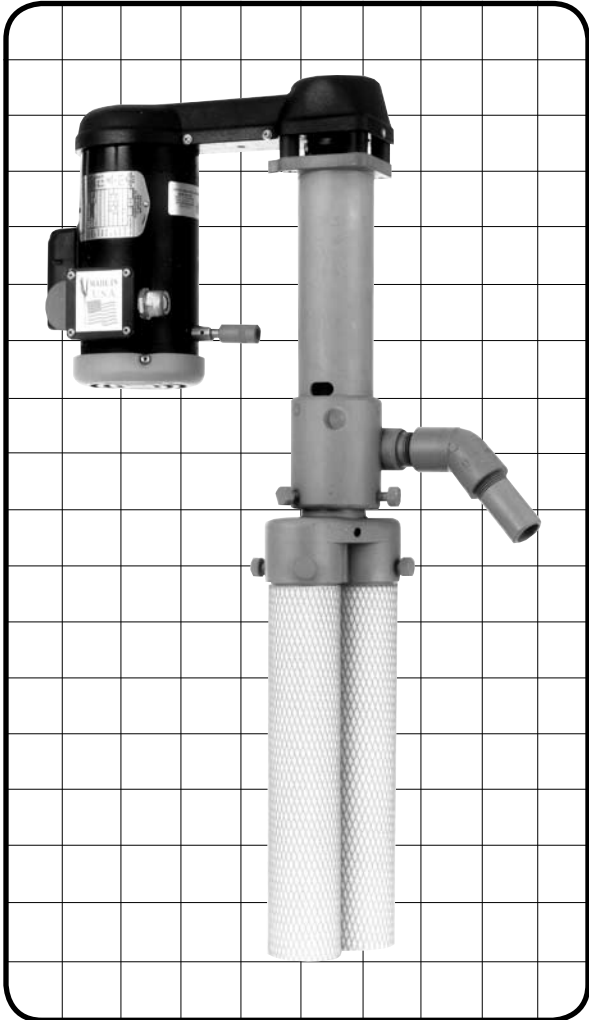

THE LOW-PROFILE FLO KING BXL2500



- **LOW PROFILE ... JUST 2" (5 cm) ABOVE THE TANK!**
- **IDEAL WHERE OVERHEAD OBSTACLES ARE PRESENT**
- **FLOW RATE OF 2500 GALLONS PER HOUR (9500 LPH)**
- **BUILT IN SEVERAL LENGTHS FOR MANY TANK CONFIGURATIONS**
- **AN ALTERNATIVE TO AIR OR MECHANICAL AGITATION**

In addition to our standard BXL2500 with over-the-side motor, this unit is available with Optional Long Motor Base to accommodate tank mounting surfaces up to 6-1/2" (16 cm) wide! Also see our larger low-profile model—the 5,000-gallon-per-hour BXL5000—on Bulletin 14.2.



Standard BXL2500

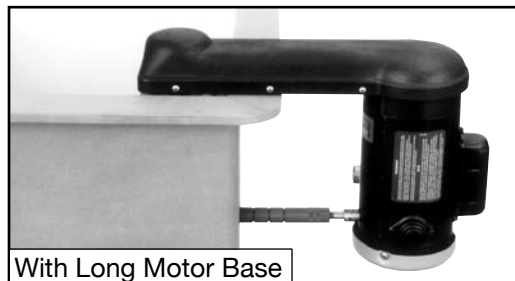

With Long Motor Base



THE FLO KING BXL2500

The BXL2500 is designed for tanks where overhead clearance is limited. The motor is inverted and positioned outside the tank, taking up only 2" (5 cm) of space above the tank. The unit provides a maximum flow rate of 2500 gallons per hour. Use it stationary on one tank or move it from tank to tank. Multiple body lengths (8", 10", 12", and 14") enable use of the BXL2500 in tanks with varying solution levels and depths. The BXL2500 comes ready to operate and includes the items shown in the labeled photograph below. For best results in most metal finishing solutions, use the BXL2500 with our PMCA Permacore Magnum reusable or FK50 Poly-Spun disposable filter cartridges in the appropriate length.

FLO KING BXL2500 SPECIFICATION

PUMP MATERIALS: Available in CPVC, polypropylene, PVDF (Kynar), and stainless steel (see Bulletin 23.5) as pump materials of construction. Standard shaft is made of Teflon-covered 303 stainless steel. A titanium-tip or Hastelloy-C276-tip shaft is available on special-order basis. Call for prices.

FLOW RATE: 2500 gallons per hour (9500 liters per hour) at 60 Hz. A flow-rate reduction of 18%(±3%) is typical when operated at 50 Hz.

PRESSURE: 27 feet (8.2 meters) of head pressure

WEIGHT: About 25 pounds (11 kg) in CPVC, depending on pump body length

MOTOR: Epoxy-coated, TEFC, Thermally Protected. Available in single phase, 1/3 HP (250 watt), 120/240 V, 6.0/3.0 A, 50/60 HZ, 2850/3450 RPM. Specify voltage when ordering. Call for information on 3-phase motors.

RUNNING PUMP DRY DOES NOT DAMAGE MOTOR, PUMP, SEALS OR BEARINGS

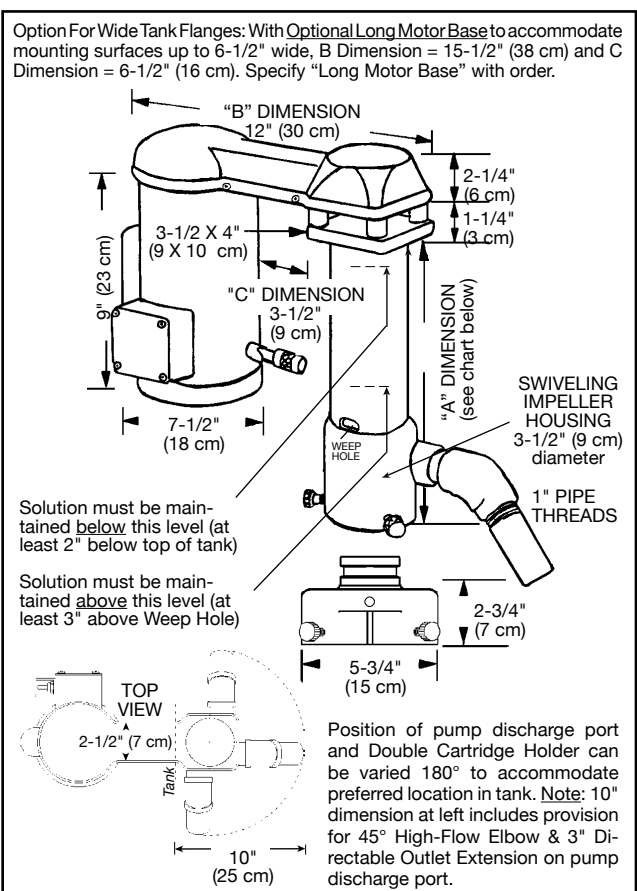
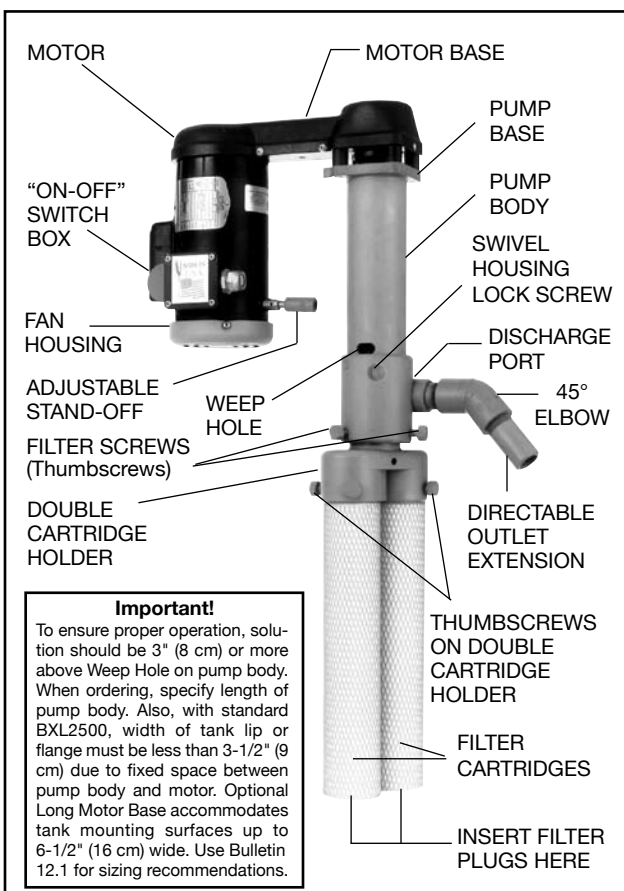

MEASUREMENT FROM BOTTOM OF PUMP BASE TO BOTTOM OF IMPELLER HOUSING ("A" DIMENSION)				
PUMP MODEL	BXL2500-8	BXL2500-10	BXL2500-12	BXL2500-14
"A" DIMENSION	10-3/4" (28 cm)	12-3/4" (32 cm)	14-3/4" (38 cm)	16-3/4" (43 cm)