

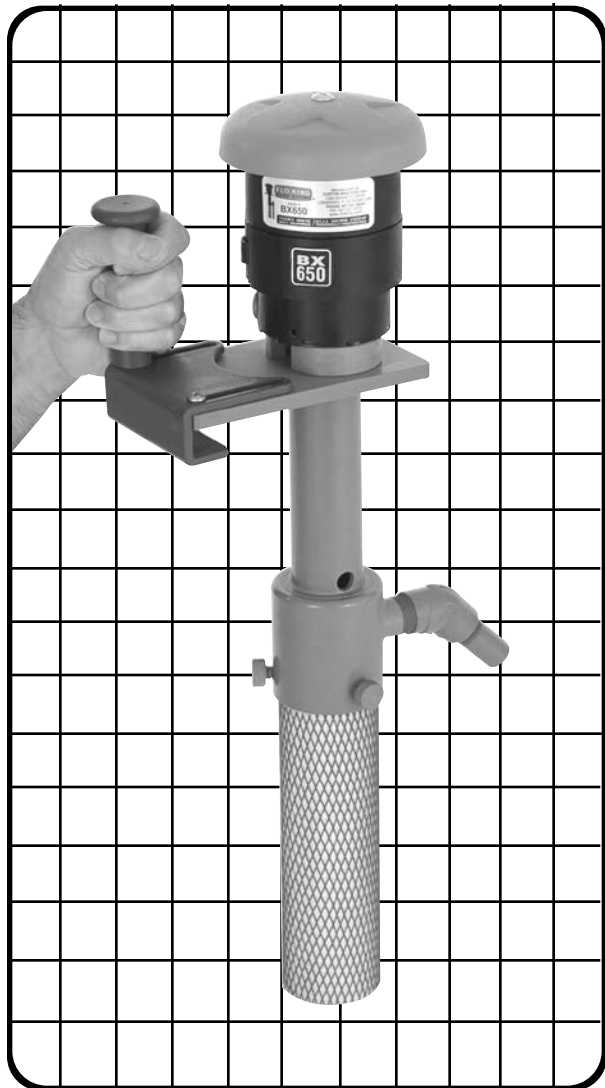

FLO KING BX650



- A FLOW RATE OF 650 GPH (2400 LPH) USING A TOTALLY ENCLOSED, FAN-COOLED MOTOR
- DEVELOPED FOR SMALL TO INTERMEDIATE-SIZE TANKS
- BUILT IN SEVERAL LENGTHS TO SATISFY FREEBOARD AND TANK DEPTH
- USE IN ONE LOCATION OR AS A PORTABLE PUMP IN MANY TANKS
- ACCEPTS STANDARD 2-1/2"-DIAMETER (6.35 cm) FILTER CARTRIDGES

Base for mounting on tank is just 4 x 6" (10 x 15 cm).



Lightweight, easy-to-use BX650 is more powerful than the Lab Series but less potent than the BX1200. Can be used with popular BX1200 accessories, such as the Double Cartridge Holder, In-Tank Floating Skimmer, and carbon treatment attachments.

★ IF YOU NEED A FILTER SYSTEM TOMORROW CALL US TODAY ★



THE FLO KING BX650

The BX650 provides a maximum flow rate of 650 gallons (2400 liters) per hour. Use it stationary on one tank or move it from tank to tank. Multiple body lengths (4", 6", 8", and 10") enable use of the BX650 in tanks with varying solution levels and depths. The BX650 comes complete, preassembled, and ready to operate and includes the items shown in the labeled photograph below. For best results in most metal-finishing solutions, use the BX650 with our PMCA Permcore Magnum reusable or FK50 Poly-Spun disposable filter cartridges in the appropriate length.

FLO KING BX650 SPECIFICATION

PUMP MATERIALS: Available in CPVC, polypropylene, PVDF (Kynar), and stainless steel as pump materials of construction. Standard shaft is made of Teflon-covered 303 stainless steel. Titanium and Hastelloy C276 alloy shafts available on special-order basis. Call for pricing.

FLOW RATE: 650 gallons per hour (2400 liters per hour) at 60 Hz. A flow-rate reduction of 18% (±3%) is typical when operated at 50 Hz.

PRESSURE: 10 feet (3 meters) of head pressure

WEIGHT: About 9 pounds (4 kg), depending on pump body length

MOTOR: Epoxy coated, rated at 1/15th HP (50 watt), single phase, 3000 rpm, TEFC, thermally protected. When ordering, specify one of the following three motors:

- 115 volts, 60 Hz, 2.6 A
- 115 volts, 50/60 Hz, 2.0 A
- 230 volts, 50/60 Hz, 1.3 A

RUNNING PUMP DRY DOES NOT DAMAGE MOTOR, PUMP, SEALS OR BEARINGS

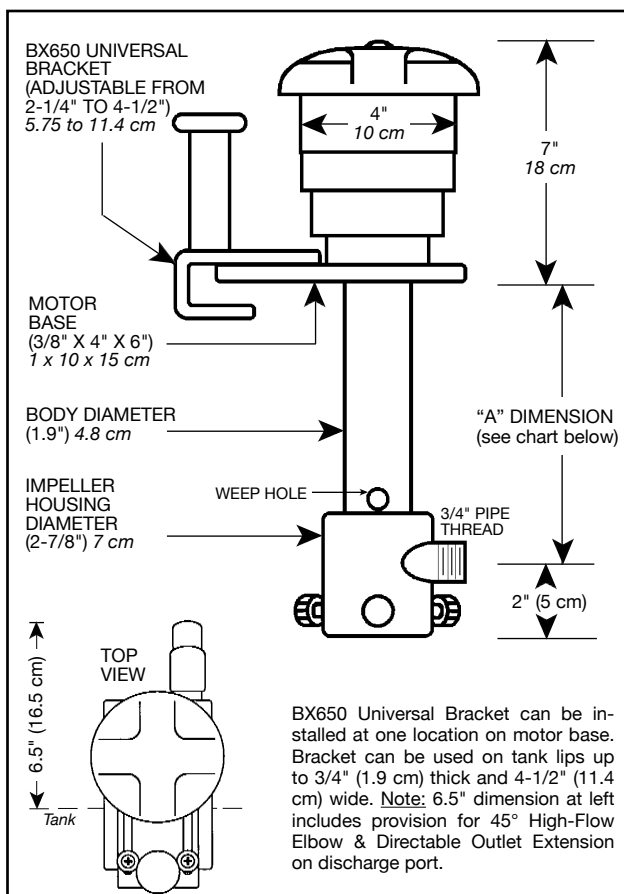
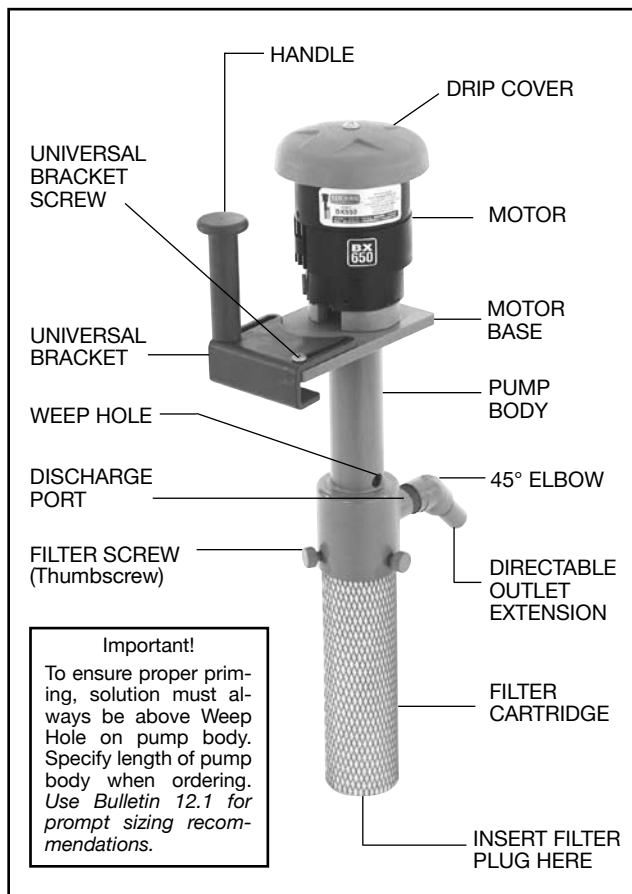

MEASUREMENT FROM BOTTOM OF MOTOR BASE TO DISCHARGE PORT ("A" DIMENSION)

PUMP MODEL	BX650-4	BX650-6	BX650-8	BX650-10
"A" DIMENSION	4-1/2" (11 cm)	6-1/2" (17 cm)	9-1/16" (23 cm)	10-3/4" (28 cm)