



# THE FLO KING BX5000



- **A FLOW RATE OF 5000 GALLONS PER HOUR (19,000 LPH) USING A TOTALLY ENCLOSED, FAN-COOLED, 3/4-HP (560-WATT) MOTOR**
- **IDEAL FOR FILTRATION OF LARGE TANKS WITHOUT FEAR OF LEAKS OR SPILLS**
- **AVAILABLE IN SEVERAL LENGTHS FOR MOST TANK CONFIGURATIONS**
- **A CLEAN SOURCE OF AGITATION ... AN ALTERNATIVE TO AIR OR MECHANICAL AGITATION**
- **HEAVY-DUTY YET STILL PORTABLE ... USE IN ONE TANK OR MANY**
- **CHANGE FILTERS QUICKLY WITHOUT TOOLS OR DOWNTIME**

**Complete, preassembled, ready to operate. No plumbing.  
No costly installation. Out of the box and into your tank!**

**★ IF YOU NEED A FILTER SYSTEM TOMORROW CALL US TODAY ★**



## THE FLO KING BX5000

The BX5000 is excellent for larger tanks or anywhere aggressive agitation is desired. Use it stationary on one tank or move it from tank to tank. Multiple body lengths (8", 10", 12", 14", 16", 18" and 20") enable use of the BX5000 in tanks with varying solution levels and depths. The BX5000 comes complete, preassembled, and ready to operate and includes the items shown in the labeled photograph below. For best results in most metal finishing solutions, use the BX5000 with our PMCA Permacore Magnum reusable or FK50 Poly-Spun disposable filter cartridges in the appropriate length.

### FLO KING BX5000 SPECIFICATION

**PUMP MATERIALS:** Available in CPVC, polypropylene, PVDF (Kynar), and stainless steel (see Bulletin 23.5) as pump materials of construction. Standard shaft is made of Teflon-covered 303 stainless steel. A titanium-tip or Hastelloy-C276-alloy-tip shaft is available on special-order basis. Call for pricing.

**FLOW RATE:** 5000 gallons per hour (19,000 liters per hour) at 60 Hz. A flow-rate reduction of 18% ( $\pm 3\%$ ) is typical when operated at 50 Hz.

**PRESSURE:** 27 feet (8.2 meters) of head pressure

**WEIGHT:** About 29 pounds (13 kg) in CPVC, depending on pump body length

**MOTOR:** Epoxy-coated, TEFC, Thermally Protected. Available in (specify voltage when ordering):

- Single phase, 3/4 HP (560 watt), 115/230 V, 9.6/4.8 A, 60 Hz, 3450 rpm.
- Single phase, 3/4 HP (560 watt), 110/220 V, 9.2/4.6 A, 50 Hz, 2850 rpm.
- Three phase, 1 HP (760 watt), 220/460 V, 3.0/1.5 A, 60 Hz, 3450 rpm. *Note: There is an additional charge for three-phase motors.*

**RUNNING PUMP DRY DOES NOT DAMAGE MOTOR, PUMP, SEALS OR BEARINGS**

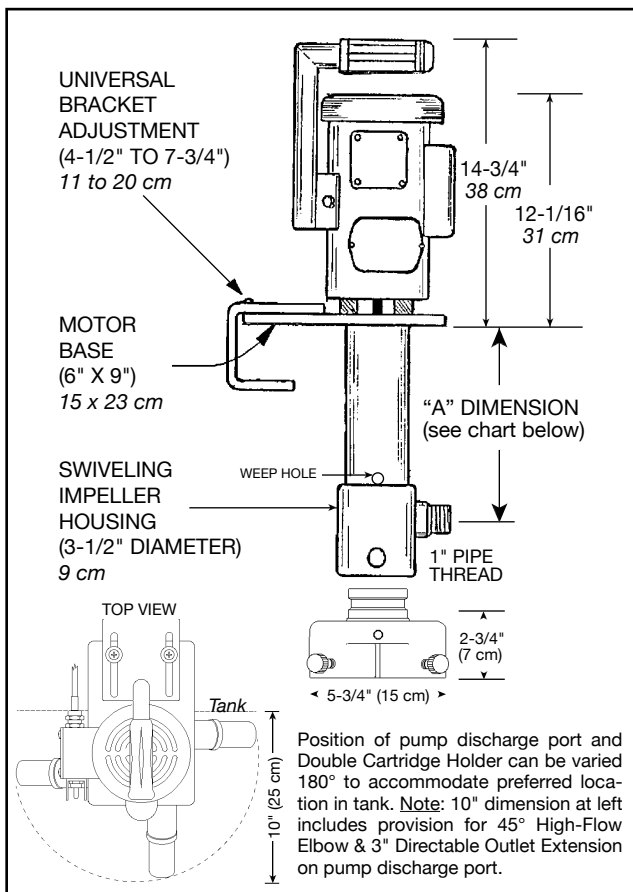
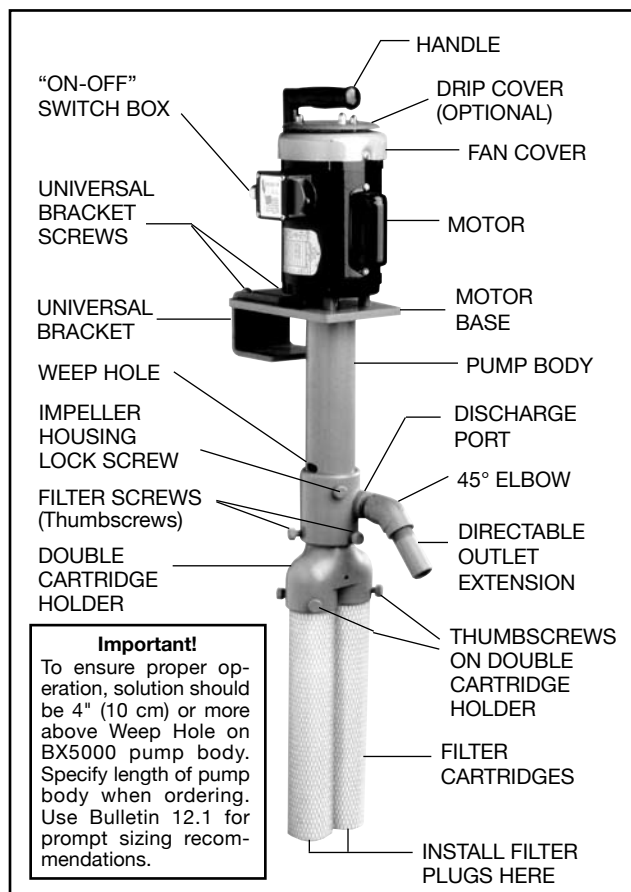

### MEASUREMENT FROM BOTTOM OF MOTOR BASE TO CENTER OF DISCHARGE PORT ("A" DIMENSION)

PUMP MODEL	BX5000-8	BX5000-10	BX5000-12	BX5000-14	BX5000-16	BX5000-18	BX5000-20
"A" DIMENSION	8-3/4" (22 cm)	10-3/4" (27 cm)	12-3/4" (32 cm)	14-3/4" (37 cm)	16-3/4" (43 cm)	18-3/4" (48 cm)	20-3/4" (53 cm)