

Series PX

Flows to 400 GPM
Pressure to 145 Ft. TDH



Model PX-10AK

Our new Penguin extended vertical immersible pumps are simple in design, efficient in performance, and self-priming when immersed in solution. Constructed completely of CPVC with PTFE wear ring, or CPVC with PVDF impeller where in contact with the solution, this pump is suitable for pumping, agitating, filtering, or circulating acid and alkaline solutions, abrasive fluids, and other corrosive solutions up to 180 degrees F maximum temperature.

Penguin Extended Vertical Pump

Features:

- CPVC Construction
- Optional PVDF Impeller Available
- No Metal Contact
- Chemical Resistant
- Self-Priming When Immersed
- Dry Run Capability w/ PVDF Impeller

Recommended Applications:

- Sump Pumping
- Transfer Pumping
- Recirculation Pumping
- Plating Solution Filtering
- Fume Scrubbing
- Waste Treatment

Standard motors are three phase and totally enclosed fan cooled, with two part epoxy coating for additional corrosion resistance. A rigid, solid stainless steel rotor/drive shaft with an oversized bearing is employed to minimize shaft alignment problems, while allowing for quick and easy bearing replacement when required. The three phase motors are shipped unwired. A standard air purge/vent screw assembly in the bottom motor housing extends the life of the bottom motor bearing when utilizing minimal 5 psi air to create a positive displacement. An optional ceramic sealing sleeve is available for added corrosion resistance in preventing fumes and condensables from contacting the metallic shaft or impeller insert.

Penguin vertical pumps are versatile, easy to install, and require a minimal amount of tank space, thus saving valuable floor space.

Series PX

Penguin Extended Vertical Pump

Performance Charts

PX-3

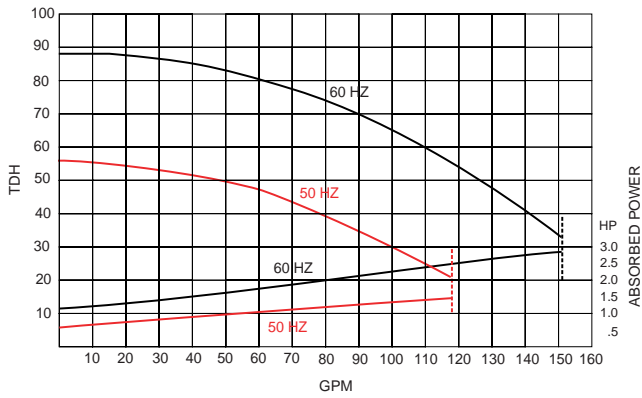

PX-5

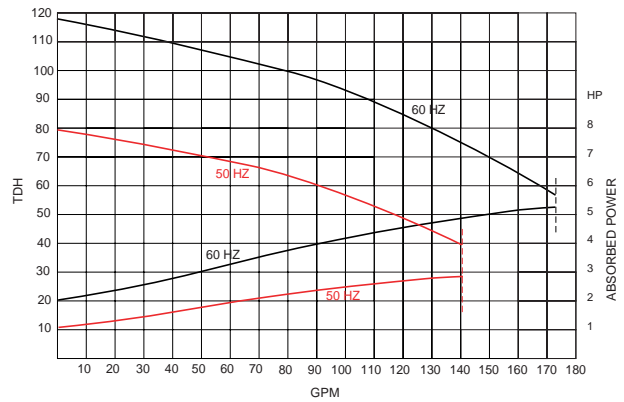

PX-7 1/2, 10 AND 15

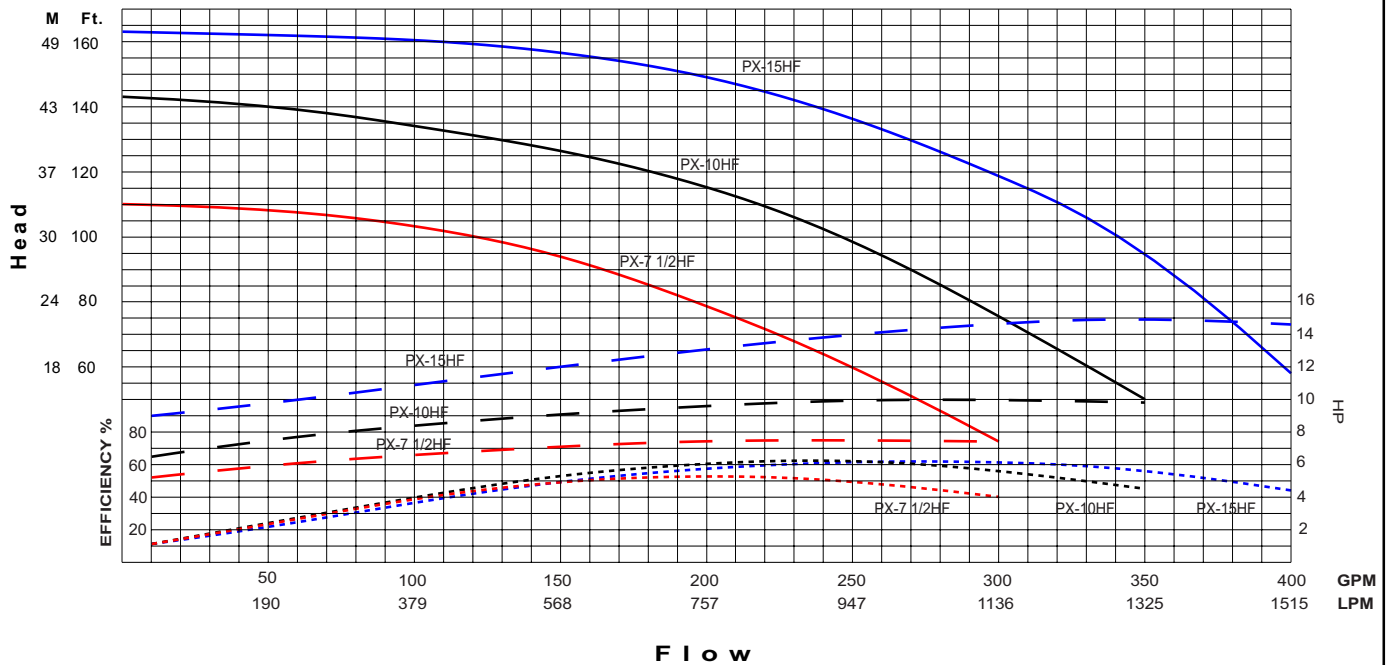

Data Based on Ambient Water, Specific Gravity 1.0
With 4" Discharge Piping @ 60 Hz (3450 RPM)

Series PX

Penguin Extended Vertical Pump

Specifications

Model	Max Flow (gpm)	Max Head (ft)	Suction	Discharge	Motor						Dimensions			
					HP	RPM	Volts	Hertz	Phase	Amps	Ht	Wth	Lth	Wt
PX-3	135	88	2 FPT	1 1/2MPT	3	3450	208-230/460	50/60	3	8.2-7.8/3.9	12	12	26	100
PX-5	172	122			5					12.2-11.6/5.8				120
PX-7 1/2	250	115	3" FPT	3" FPT	7 1/2	3450	208-230/460	50/60	3	21-19/19.5	25	36	48	310
PX-10	325	125			10					27-25/12.5				320
PX-15	400	145			15					44-40/20				330

Dimensions

Model	B	C	D	F	G	H	J
PX-3	7	12	21	36 3/4	12	2 1/8	7
PX-5							
PX-7 1/2							
PX-10	13 1/8	24 1/4	21 5/8	47	17	4 5/8	13 1/8
PX-15							

PX-3 & 5

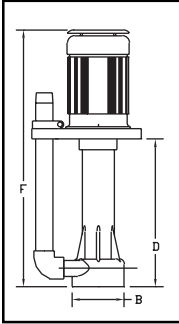

PX-7 1/2, 10 & 15

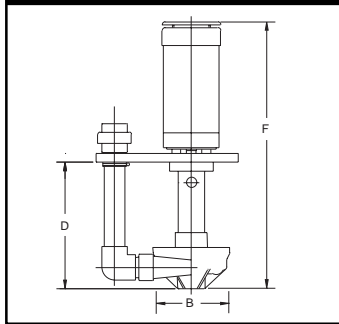

Top View

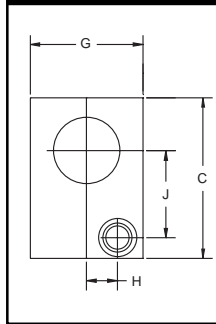

Nomenclature

PX	-	3	A	C	-	HF
Penguin Extended Pump		Horsepower	Construction Material/ O-Ring Elastomer Material	Impeller Material Construction		Impeller/Housing Construction
		3=3 5=5 7 1/2=7 1/2 10=10 15=15	A=CPVC/EPR	None=Standard C = PVDF		HF=High Flow
Not all combinations are available						

Your Stocking Distributor:

Chemical Distributors, Inc. - Buffalo, NY - 800.777.2436 - Fax 716.856.7115